

Vi3026

26-port Gigabit Ethernet L2+ Managed PoE Switch

Features

- Provides 26 Gb Ethernet ports with 24 PoE ports plus 6 SFP ports
- 24 ports at 802.3af PoE and up to 12-ports at 802.3at (30W)
- Two 1Gbps independent uplink and downlink ports allow for full use of all 24-ports
- SNMP for communicating error messaging to local computers
- Automatic IP and PoE connection and reconnection
- Automatic MAC identification for all connected devices
- Individual IP Source Guard for protecting ports
- Supports Jumbo Frames up to 9600 bytes
- High Bandwidth 52Gbyte switching fabric
- Virtual Network Switch Stacking



The Vi3026 is the next generation L2+ managed switch designed for PoE+ and high Bandwidth network applications. It provides a reliable infrastructure for your business network. The Vi3026 delivers unique intelligent features that are needed to improve the availability of your critical business applications with unique PoE monitoring and application features. The Vi3026 can be programmed to apply PoE individually timed to each port to lower the potential for power overload that can result in damage. Total power and PoE are monitored for over power conditions. Programmable IP and PoE connection reduces connection failure potentials and will automatically re-establish connections and apply PoE, reducing down time and field service calls. It can easily support any Ethernet device such as IP Phones, IP Cameras, and Wireless base stations; thus helping you to create a more efficient, better networked workforce. Full CLI documentation is provided for custom integration.

Vigitron Vi3026 is designed to meet the growing power and bandwidth requirements for IP security cameras by providing both reliability and conductivity with the ability to locate and determine network system problems:

- High PoE Power Budget: Total 525W power supply with 370W PoE budget providing 24-ports at full 15.4 W (802.3af) and 12-ports at full 30W (802.3at) with 10 watt PoE power overhead reserve.
- Programmable Video/Data packet transmission up to the Jumbo Frame limit of 9600 bytes for transmitting the highest mega pixel cameras at 100Mbps and 1Gps port speeds.
- Wide 52Gbps switch fabric assuring all required bandwidth, even with all ports at their maximum bandwidth assuring video and data quality.
- Automatic connection and re-connection with PoE application for more reliable startups reducing down time potentials.
- Programmable multicasting for compatibility and performance with largest IP video network systems.
- Programmable Rapid Spanning Tree for redundant network configuration assuring maintenance of network communication using multiple paths.
- Virtual Stacking features eliminate the need for all switches to be at the same location, while providing access to all switches anywhere on the network using one IP address.
- Automatic MAC address detection for connected devices for easy connection verification and security programming.
- Easy port feature provides one step port settings for IP camera, VoIP and wireless connections.

Technical Specification

Electrical

Ethernet Interface	RJ-45 10/100Mbps/ 1Gbps port
Throughput	95.232Mbps
Power	100-240 VAC 50~60 Hz, internal , universal
Status LEDs	Power, traffic, link and PoE
Switch Capacity	38.69 MPPS, 52 Gbps
Ports	Total System Ports: 26 GbE RJ-45 Ports: 20 GbE RJ-45/SFP(100/1G) Combo: 4 SFP (100/1G): 2
PoE Compatibility	IEEE 802.3af, IEEE 802.3at Supports per port PoE configuration function Supports per port PoE scheduling to turn on/off the PoE
Jumbo Frame Support	Yes
Mac Table	Up to 8K MAC addresses

Regulatory

FCC	Part 15, Class A
Safety	CE, UL, cUL
Environmental	WEEE/RoHS

Environmental

Humidity	0 to 95%, non-condensing
Temperature	Operating: 32° to 104° F; 0° to 40° C Storage: -4° to 158° F; -20° to 70° C
Operating Humidity	10% to 90% , relative, noncondensing

Mechanical

Dimensions	442 x 44 x 300 mm; 17.4 x 1.7 x 11.8 in (HxWxL)
Weight	5.1Kg; 11.3 lb
Material	Extruded Aluminum

Accessories

- Switch
- Power Cord
- Mounting Kit
- Console Cable
- CD-ROM includes: Operations Manual, CLI Document, Quick Install Guide, and Quick Set-Up Guide

Minimum Requirements

- Web browser: Mozilla Firefox version 2.5 or later, Microsoft Internet Explorer version 6 or later
- Category 5 Ethernet network cable
- TCP/IP, network adapter, and network operating system (such as Microsoft Windows, or Linux) installed on each computer in network.

*Specifications subject to change without notice.

Ordering Information

Part No. Description

Vi3026	Gigabit Ethernet L2 Plus Managed PoE Switch
---------------	---

Compatible ANSI/IEEE Standards

Standard	Description
IEEE 802.3	Ethernet 10baseT UTP
IEEE 802.3u	Fast Ethernet 1000baseTX UTP
IEEE 802.3ab	Ethernet 1000baseTX UTP
IEEE 802.3z	Ethernet 1000baseX
IEEE 802.3x	Flow control Capability
IEEE 802.1q	VLAN
IEEE 802.1p	Class of Service
IEEE 802.1x	Access Control
IEEE 802.1d	Spanning Tree
IEEE 802.1w	Rapid Spanning Tree
IEEE 802.1s	Multiple Spanning Tree
IEEE 802.1ad	Link Aggregation Control Protocol (LACP)
IEEE 802.1AB	Link Layer Discovery Protocol (LLDP)
IEEE 802.3az	Energy Efficient Ethernet Task
IEEE 802.3ad	Trunking
IEEE 802.1Q	Tag Based VLAN
ANSI/IEEE 802.3	Auto – negotiation



TEL (+1) 858-484-5209 • FAX (+1) 858-484-1205

7810 Trade Street, Suite 100, San Diego, CA 92121, USA • support@vigatron.com • www.vigatron.com

© Copyright 2022 Vigatron, Inc.

Technical Specification

Layer 2 Plus

Spanning Tree Protocol (STP)	Standard Spanning Tree 802.1d Rapid Spanning Tree (RSTP) 802.1w Multiple Spanning Tree (MSTP) 802.1s
Trunking	Link Aggregation Control Protocol (LACP) IEEE 802.3ad <ul style="list-style-type: none">• Up to 13 groups• Up to 16 ports per group
VLAN	Supports up to 4K VLANs simultaneously (out of 4096 VLAN IDs) <ul style="list-style-type: none">• Port-based VLAN• 802.1Q tag-based VLAN• MAC-based VLAN• Management VLAN• Private VLAN Edge (PVE)
Easy Port	Voice or IP video is automatically assigned to specific VLANS with appropriate levels of QoS.
Generic VLAN Registration (GVRP)	Protocol for automatically propagating and configuring VLANs in a bridged domain.
DHCP Relay (Layer 2)	Relay of DHCP traffic to DHCP server in different VLAN. Works with DHCP Option 82.
IGMP v1/v2/v3 Snooping	IGMP limits bandwidth-intensive multicast traffic to only the requesters. Supports 1024 multicast groups (source-specific multicasting is also supported)
IGMP Querier	IGMP querier is used to support a Layer 2 multicast domain of snooping switches in the absence of a multicast router.
IGMP Proxy	Supports IGMP Proxy
MLD v1/v2 Snooping	Delivers IPv6 multicast packets only to the required receivers.

Security

Secure Shell (SSH)	SSH secures Telnet traffic in or out of the switch, SSH v1 and v2 are supported.
Secure Sockets Layer (SSL)	SSL encrypts the http traffic, allowing advanced secure access to the browser-based management GUI in the switch.
IEEE 802.1X	IEEE802.1X: RADIUS authentication, authorization and accounting, MD5 hash, guest VLAN, single/multiple host mode and single/multiple sessions. Supports IGMP-RADIUS based 802.1X Dynamic VLAN assignment
Layer 2 isolation Private VLAN Edge (PVE)	PVE (also known as protected ports) provides L2 isolation between clients in the same VLAN. Supports multiple uplinks.
Port Security	Locks MAC Addresses to ports, and limits the number of learned MAC addresses.
IP Source Guard	Prevents datagram with spoofed addresses from being in the network.
Radius/ Tacacs+	Supports RADIUS and TACACS+ authentication. Switch as a client.
Storm control	Prevents traffic on a LAN from being disrupted by a broadcast, multicast, or unicast storm on a port.
ACLs	Drop or rate limitation based on source and destination MAC, VLAN ID or IP address, protocol, port, differentiated services code point (DSCP) / IP precedence, TCP/ UDP source and destination ports, 802.1p priority, Ethernet type, Internet Control Message Protocol (ICMP) packets, IGMP packets, TCP flag. Supports up to 256 entries.



Technical Specification

Quality of Service

Hardware Priority Queue	Supports 8 hardware queues
Scheduling	Strict priority and weighted round-robin (WRR). Queue assignment based on DSCP and class of service (802.1p/ CoS).
Classification	Port based; 802.1p VLAN priority based; IPv4/IPv6 precedence/ type of service (ToS) / DSCP based; Differentiated Services (DiffServ); classification and re-marking ACLs, trusted QoS.
Rate Limiting	Ingress policer; egress shaping and rate control; per VLAN, per port and flow based.
IPv6/IPv4 Applications	Web/ SSL, Telnet/ SSH, ping, Simple Network Time Protocol (SNTP), Trivial File Transfer Protocol (TFTP), SNMP, RADIUS, Syslog, DNS Client, protocol-based VLANs.

Management

Web GUI Interface	Built-in switch configuration utility for browser-based device configuration (HTTP/ HTTPs). Supports configuration, system dashboard, maintenance, and monitoring.
Dual Image	Dual image provides independent primary and secondary OS files for backup while upgrading.
SNMP	SNMP version1, 2c and 3 with support for traps, and SNMP version 3 user-based security model (USM).
(RMON) Remote Monitoring	Embedded RMON software agent supports RMON groups 1,2,3,9 (history, statistics, alarms, and events) for enhanced traffic management, monitoring and analysis.
IPv4 and IPv6 dual stack	Coexistence of both protocol stacks to migration.
Firmware Upgrade	<ul style="list-style-type: none">• Web browser upgrade (HTTP/ HTTPs) and TFTP• Upgrade through console port as well
Port mirroring	Traffic on a port can be mirrored to another port for analysis with a network analyzer or RMON probe. Up to N-1 (N is Switch's Ports) ports can be mirrored to single destination port. A single session is supported.
Easy Port Configuration	Easily to configure of clients' QoS and Security capabilities.
Other	Single IP management; HTTP/HTTPs; SSH; RADIUS; DHCP Client/ DHCPv6 Client; SNTP; cable diagnostics; ping; syslog; Telnet client (SSH secure support).
s-Flow	The industry standard technology for monitoring high speed switched networks. It gives complete visibility into the use of networks enabling performance optimization, accounting/billing for usage, and defense against security threats.
UPnP	The Universal Plug and Play Forum, an industry group of companies working to enable device-to-device interoperability by promoting Universal Plug and Play.

Green Ethernet

Link Detection	Compliant with IEEE802.3az Energy Efficient Ethernet Task Force. Automatically turns off power on Gigabit Ethernet RJ-45 port when detecting link down or idle of client. Active mode is resumed without loss of any packets when the switch detects the link up.
----------------	---

Discovery

Link Layer Discovery Protocol (LLDP)	Used by network devices for advertising their identities, capabilities, and neighbors on a IEEE 802 local area network, principally wired Ethernet.
--------------------------------------	---



Notes

Benefits

The Vi3026 provides security, performance, quality of services, central management, and other network control capabilities. Optimized and customized design, and affordable pricing, it best fit for SMB or entry-level enterprise solution. It provides:

- **Excellent Performance and Reliability:** The Vi3026 passed rigorous testing to deliver excellent performance. As a managed switching solution, it also provides the flexibility to manage and prioritize suitable-bandwidth traffic for IP Cameras and Voice.
- **Easy, Simple Deployment and Configuration:** The device manager software provides an intuitive, web-based interface to simplify deployment, advanced security (ACLs, IP Source guard, VLAN...etc), and quality of service (QoS) traffic prioritization. This switch uses IEEE802.1AB LLDP to automatically discover all the devices (those support LLDP) connected to the network. For more advanced capabilities and easy-to-use graphical tools, such as EPC (Easy-Port-Configuration), it provides preset options for easily configuring each port of the switch. It will make setup easy when operating with IP phones, IP cameras or Wifi APs.
- **Strong Security:** The switch provides an advanced security and gives you tight control to safeguard the network from unauthorized users. Advanced security features include:
 - Secure remote management by supporting SSH, SSL, and SNMPv3 connection which encrypt the packet content at each session.
 - Extensive access control lists (ACLs) to restrict sensitive portions of the network from unauthorized users or guests.
 - Guest virtual LANs (VLANs) provide Internet connectivity to guests while isolating critical traffic from guest traffic.
 - IP Source Guard to prevent datagrams with spoofed addresses from being in the network.
 - IEEE802.1X port security to tightly limit access to specific segments of network.
- **Video and Voice Support:** The switch can be easily configured with the specific VLAN and QoS parameters to prioritize IP Cameras and voice traffic whereas ensure consistent network performance for all services.
- **Advanced Network Management Capabilities:** As a managed switch, it helps you to use a variety of advanced managing features to manage traffic over your network. Features include:
 - Support IPv6: As the IP network addressing scheme evolves to accommodate more devices, Vi3026 supports IPv6, the newest version of the Internet Protocol, as well as the previous IPv4 standard. As the result, you have the ability to move up to the next generation of networking applications without an extensive equipment upgrade.
 - Remote management: Using Simple Network Management Protocol (SNMP) and IEEE802.1AB LLDP, you can configure and manage Vi3026 and other Vigitron switches in the network remotely, instead of having to directly connect to them.
- **Energy Efficiency:** Vi3026 is designed to comply with IEEE802.3az, energy efficient Ethernet protocol, reducing energy costs without compromising performance. Power-saving features include:
 - The latest application-specific integrated circuits (ASICs), using low-power technology, allow for lower power consumption and thinner, more efficient designs.
 - Embedded intelligence to adjust signal strength based on cable length.
- **Expansion Ports:** Featuring 20 Gigabit UTP ports, the Vi3026 also offers 4 Combo RJ-45/SFP for a total of 24 ports and speeds up to 1Gbps, and 2 100/1G SFP ports for uplinks to Fast Ethernet or Gigabit Ethernet fiber optic networks.



Mechanical Drawings

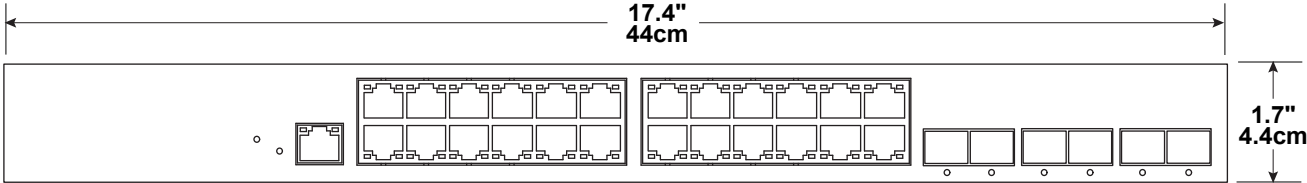

Front View

Application Drawings

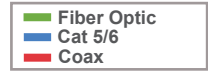

Connecting IP cameras over Multiple Medias

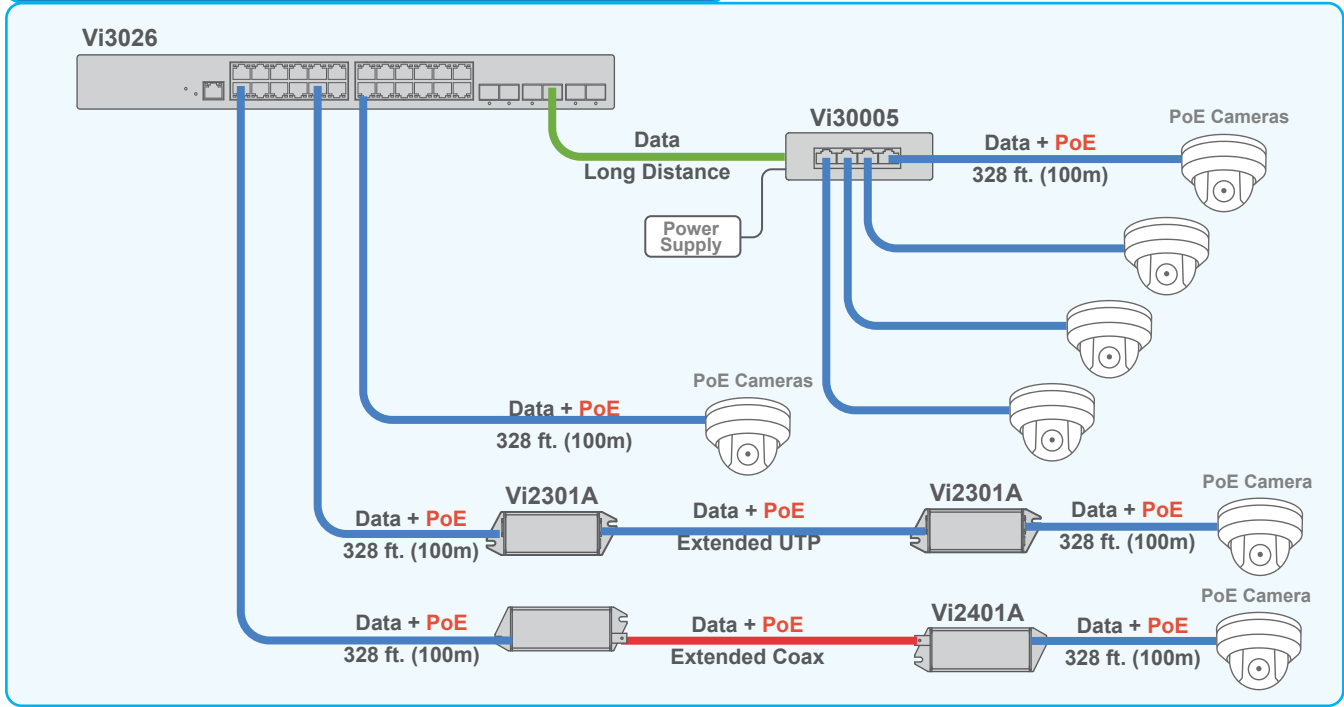

The Vi3026 can provide can be used to connect IP cameras over fiber optics and Extended UTP and Coax.